

STANLEY[®]

FATMAX[®]

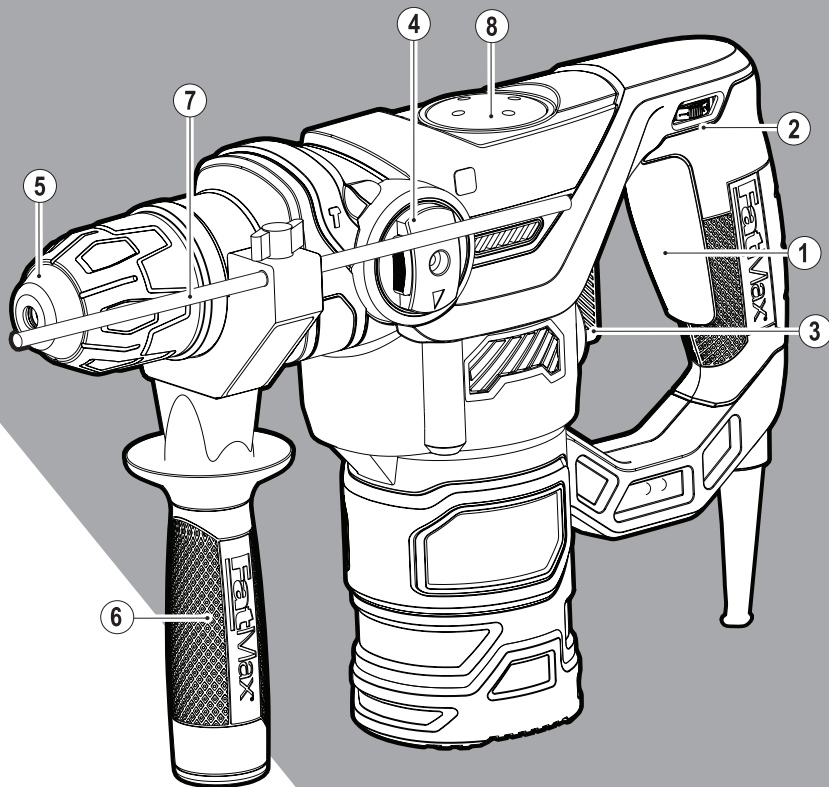

FME1250

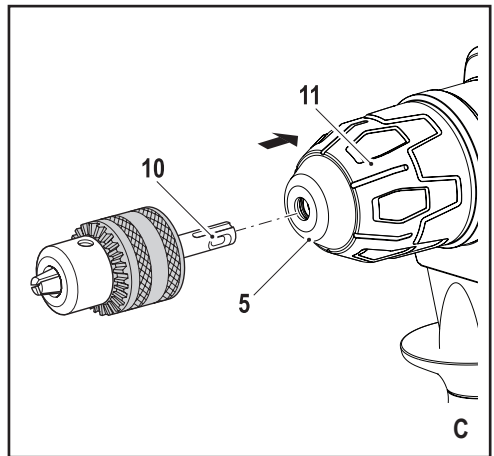
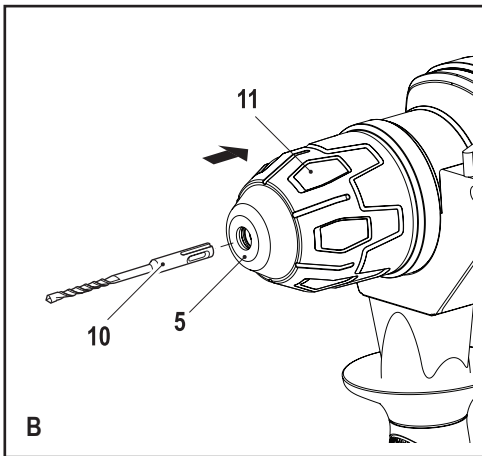
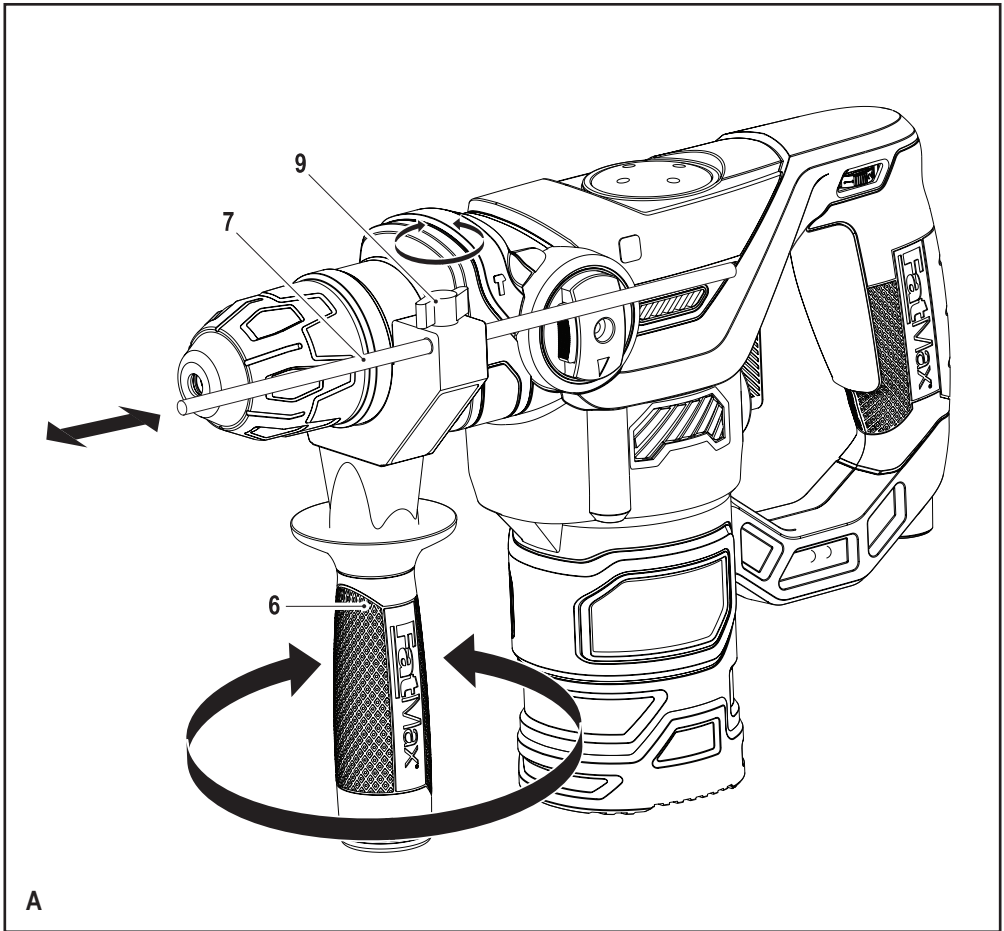

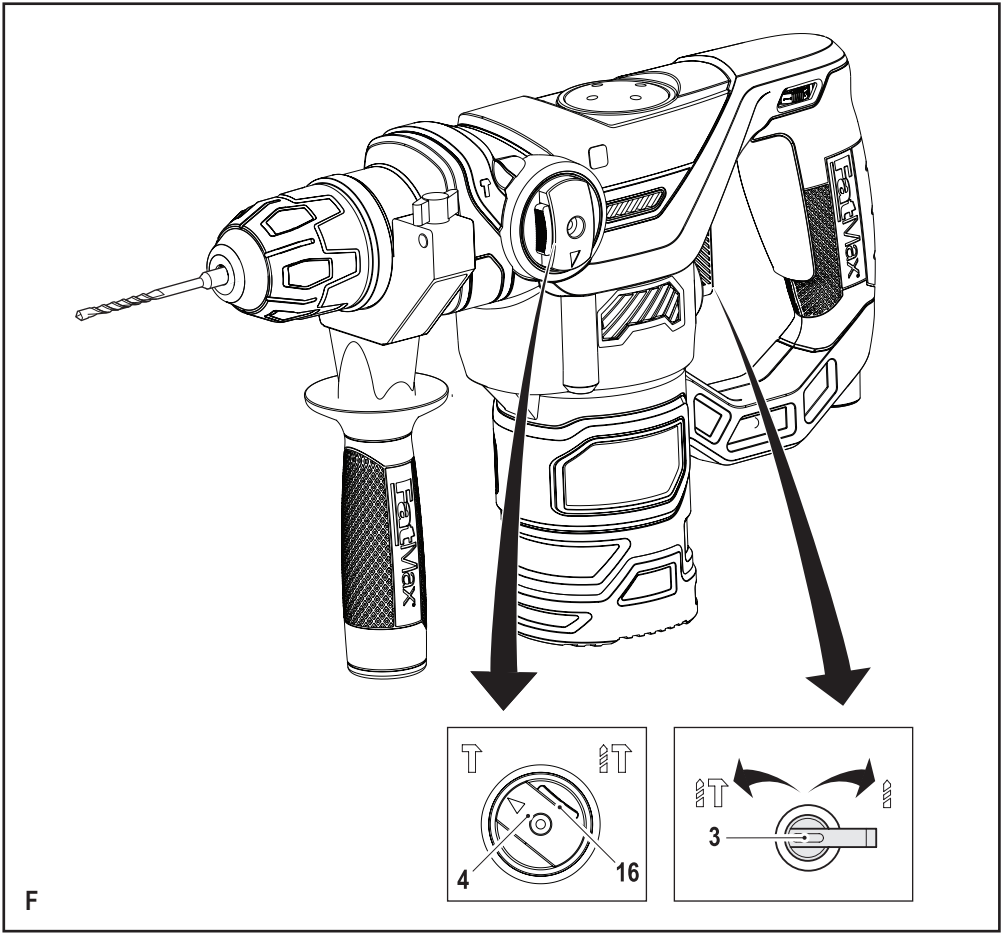
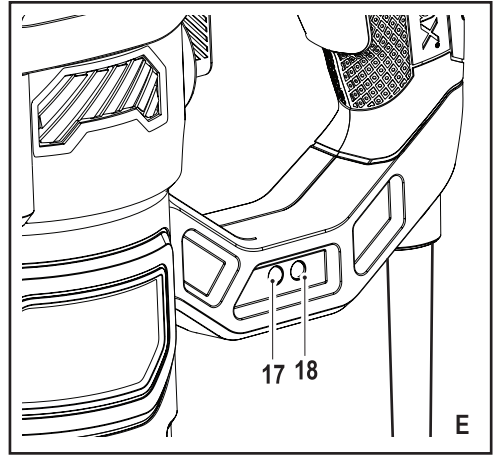
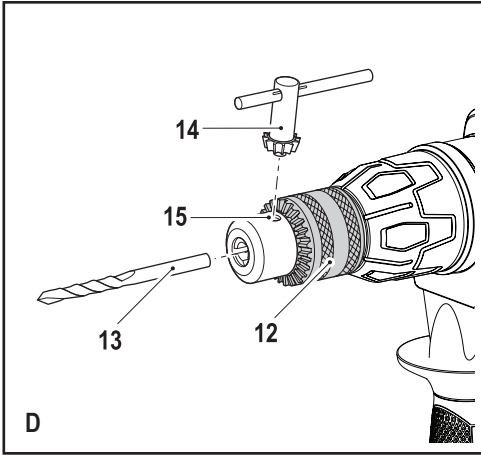

Intended use

Your Stanley FatMax rotary hammer drill has been designed for drilling in wood, metal, plastics, and masonry as well as for screwdriving and light chiselling applications. This tool is intended for professional and private, non professional users.

Safety instructions

General power tool safety warnings



Warning! Read all safety warnings and all instructions. Failure to follow the warnings and instructions listed below may result in electric shock, fire and/or serious injury.

Save all warnings and instructions for future reference.

The term "power tool" in the warnings refers to your mains operated (corded) power tool or battery operated (cordless) power tool.

1. **Work area safety**
 - a. **Keep work area clean and well lit.** Cluttered or dark areas invite accidents.
 - b. **Do not operate power tools in explosive atmospheres, such as in the presence of flammable liquids, gases or dust.** Power tools create sparks which may ignite the dust or fumes.
 - c. **Keep children and bystanders away while operating a power tool.** Distractions can cause you to lose control.
2. **Electrical safety**
 - a. **Power tool plugs must match the outlet. Never modify the plug in any way. Do not use any adapter plugs with earthed (grounded) power tools.** Unmodified plugs and matching outlets will reduce risk of electric shock.
 - b. **Avoid body contact with earthed or grounded surfaces such as pipes, radiators, ranges and refrigerators.** There is an increased risk of electric shock if your body is earthed or grounded.
 - c. **Do not expose power tools to rain or wet conditions.** Water entering a power tool will increase the risk of electric shock.
 - d. **Do not abuse the cord. Never use the cord for carrying, pulling or unplugging the power tool. Keep cord away from heat, oil, sharp edges or moving parts.** Damaged or entangled cords increase the risk of electric shock.
 - e. **When operating a power tool outdoors, use an extension cord suitable for outdoor use.** Use of a cord suitable for outdoor use reduces the risk of electric shock.
 - f. **If operating a power tool in a damp location is unavoidable, use a residual current device (RCD) protected supply.** Use of an RCD reduces the risk of electric shock.
3. **Personal safety**
 - a. **Stay alert, watch what you are doing and use common sense when operating a power tool. Do not use a power tool while you are tired or under the influence of drugs, alcohol or medication.** A moment of inattention while operating power tools may result in serious personal injury.
 - b. **Use personal protective equipment. Always wear eye protection.** Protective equipment such as dust mask, non-skid safety shoes, hard hat, or hearing protection used for appropriate conditions will reduce personal injuries.
 - c. **Prevent unintentional starting. Ensure the switch is in the off-position before connecting to power source and/or battery pack, picking up or carrying the tool.** Carrying power tools with your finger on the switch or energising power tools that have the switch on invites accidents.
 - d. **Remove any adjusting key or wrench before turning the power tool on.** A wrench or a key left attached to a rotating part of the power tool may result in personal injury.
 - e. **Do not overreach. Keep proper footing and balance at all times.** This enables better control of the power tool in unexpected situations.
 - f. **Dress properly. Do not wear loose clothing or jewellery. Keep your hair, clothing and gloves away from moving parts.** Loose clothes, jewellery or long hair can be caught in moving parts.
 - g. **If devices are provided for the connection of dust extraction and collection facilities, ensure these are connected and properly used.** Use of dust collection can reduce dust-related hazards.
4. **Power tool use and care**
 - a. **Do not force the power tool. Use the correct power tool for your application.** The correct power tool will do the job better and safer at the rate for which it was designed.
 - b. **Do not use the power tool if the switch does not turn it on and off.** Any power tool that cannot be controlled with the switch is dangerous and must be repaired.
 - c. **Disconnect the plug from the power source and/or the battery pack from the power tool before making any adjustments, changing accessories, or storing power tools.** Such preventive safety measures reduce the risk of starting the power tool accidentally.

- d. **Store idle power tools out of the reach of children and do not allow persons unfamiliar with the power tool or these instructions to operate the power tool.** Power tools are dangerous in the hands of untrained users.
 - e. **Maintain power tools. Check for misalignment or binding of moving parts, breakage of parts and any other condition that may affect the power tools operation. If damaged, have the power tool repaired before use.** Many accidents are caused by poorly maintained power tools.
 - f. **Keep cutting tools sharp and clean.** Properly maintained cutting tools with sharp cutting edges are less likely to bind and are easier to control.
 - g. **Use the power tool, accessories and tool bits etc. in accordance with these instructions, taking into account the working conditions and the work to be performed.** Use of the power tool for operations different from those intended could result in a hazardous situation.
5. **Service**
- a. **Have your power tool serviced by a qualified repair person using only identical replacement parts.** This will ensure that the safety of the power tool is maintained.
 - b. **Power to the tool should always be supplied via residual current device with a rated residual current of 30mA or less.**

Additional power tool safety warnings



Warning! Additional safety warnings for rotary and chiselling hammers

- ◆ **Wear ear protectors when impact drilling.** Exposure to noise can cause hearing loss.
- ◆ **Use auxiliary handle(s) if supplied with the tool.** Loss of control can cause personal injury.
- ◆ **Hold power tool by insulated gripping surfaces when performing an operation where the cutting accessory may contact hidden wiring or its own cord.** Cutting accessory contacting a "live" wire may make exposed metal parts of the power tool "live" and shock the operator.
- ◆ **Never use a chisel accessory in rotary mode.** The accessory will bind in the material and rotate the drill.
- ◆ **Use clamps or another practical way to secure and support the workpiece to a stable platform.** Holding the work by hand or against your body leaves it unstable and may lead to loss of control.
- ◆ Before drilling into walls, floors or ceilings, check for the location of wiring and pipes.
- ◆ Avoid touching the tip of a drill bit just after drilling, as it may be hot.

- ◆ This tool is not intended for use by persons (including children) with reduced physical, sensory or mental capabilities, or lack of experience and knowledge, unless they have been given supervision or instruction concerning use of the appliance by a person responsible for their safety. Children should be supervised to ensure that they do not play with the appliance.
- ◆ The intended use is described in this instruction manual. The use of any accessory or attachment or performance of any operation with this tool other than those recommended in this instruction manual may present a risk of personal injury and/or damage to property.
- ◆ Use a face or dust mask whenever the operations may produce dust or flying particles.

Safety of others

- ◆ This appliance is not intended for use by persons (including children) with reduced physical, sensory or mental capabilities, or lack of experience and knowledge, unless they have been given supervision or instruction concerning use of the appliance by a person responsible for their safety.
- ◆ Children should be supervised to ensure that they do not play with the appliance.

Residual risks.

Additional residual risks may arise when using the tool which may not be included in the enclosed safety warnings. These risks can arise from misuse, prolonged use etc.

Even with the application of the relevant safety regulations and the implementation of safety devices, certain residual risks can not be avoided. These include:

- ◆ Injuries caused by touching any rotating/moving parts.
- ◆ Injuries caused when changing any parts, blades or accessories.
- ◆ Injuries caused by prolonged use of a tool. When using any tool for prolonged periods ensure you take regular breaks.
- ◆ Impairment of hearing.
- ◆ Health hazards caused by breathing dust developed when using your tool (example:- working with wood, especially oak, beech and MDF.)

Vibration

The declared vibration emission values stated in the technical data and the declaration of conformity have been measured in accordance with a standard test method provided by EN 60745 and may be used for comparing one tool with another. The declared vibration emission value may also be used in a preliminary assessment of exposure.

Warning! The vibration emission value during actual use of the power tool can differ from the declared value depending on the ways in which the tool is used. The vibration level may increase above the level stated.

When assessing vibration exposure to determine safety measures required by 2002/44/EC to protect persons regularly using power tools in employment, an estimation of vibration exposure should consider, the actual conditions of use and the way the tool is used, including taking account of all parts of the operating cycle such as the times when the tool is switched off and when it is running idle in addition to the trigger time.

Labels on tool

The following pictograms are shown on the tool:



Warning! To reduce the risk of injury, the user must read the instruction manual.

Electrical safety



This tool is double insulated; therefore no earth wire is required. Always check that the power supply corresponds to the voltage on the rating plate.

- ◆ If the supply cord is damaged, it must be replaced by the manufacturer or an authorised Stanley Europe Service Centre in order to avoid a hazard.

Features

This tool includes some or all of the following features.

1. On/Off switch
2. Speed selector dial
3. Drilling mode selector
4. Operating mode selector
5. Tool holder
6. Side handle
7. Depth stop
8. Grease cap

Assembly

Warning! Before assembly, make sure that the tool is switched off and unplugged.

Fitting the side handle (fig. A)

- ◆ Turn the grip counterclockwise until you can slide the side handle (6) onto the front of the tool as shown.
- ◆ Rotate the side handle into the desired position.
- ◆ Tighten the side handle by turning the grip clockwise.

Fitting and setting the depth stop (fig. A)

- ◆ Slacken the knob (9).
- ◆ Insert the depth stop (7) into the mounting hole as shown.
- ◆ Set the depth stop (7) to the desired position. The maximum drilling depth is equal to the distance between the tip of the drill bit and the front end of the depth stop.
- ◆ Tighten the knob (9).

Fitting an accessory (fig. B - D)

- ◆ Clean and grease the shank (10) of the accessory.
- ◆ Pull back the sleeve (11) and insert the shank into the tool holder (5).
- ◆ Push the accessory down and turn it slightly until it fits into the slots.
- ◆ Pull on the accessory to check if it is properly locked. The hammering function requires the accessory to be able to move axially several centimetres when locked in the tool holder.
- ◆ To remove the accessory, pull back the sleeve (11) and pull out the accessory.

Keyed chuck (fig. D)

- ◆ Open the chuck by turning the sleeve (12) anti-clockwise.
- ◆ Insert the bit shaft (13) into the chuck.
- ◆ Insert the chuck key (14) into each hole (15) in the side of the chuck and turn clockwise until tight.

Use

Warning! Let the tool work at its own pace. Do not overload.

Warning! Before drilling into walls, floors or ceilings, check for the location of wiring and pipes.



Warning! Do not apply chisels when the tool is in the drilling mode.

Selecting the operating mode (fig. F)



The tool can be used in three operating modes.

- ◆ To operate the drilling mode selector (3), rotate it towards the required position, as indicated by the symbols.
- ◆ To operate the operating mode selector (4), push the unlock button (16) and rotate the selector towards the required position, as indicated by the symbols.



Drilling

- ◆ For drilling in steel, wood and plastics, and for screwdriving set the operating mode selector (4) to the  position and the drilling mode selector (3) to the  position.

Hammer drilling

- ◆ For hammer drilling in masonry and concrete, set the operating mode selector (4) to the  position and the drilling mode selector (3) to the  position. When hammering, the tool should not bounce and run smoothly. If necessary, increase the speed.

Hammering

- ◆ For hammering with spindle lock, and for light chiselling and chipping, set the operating mode selector (4) to the  position and the drilling mode selector (3) to the  position.
- ◆ When changing from hammer drilling to chiselling, turn the chisel to the desired position. If resistance is felt during mode change, slightly turn the chisel to engage the spindle lock.

Switching on and off

- ◆ Select the required speed by turning the speed selector dial (2).
- ◆ To switch the tool on, press the on/off switch (1).
- ◆ To switch the tool off, release the on/off switch.

Brush monitor (fig. E)

Your tool has a built in system that monitors the health of the brushes.

- ◆ Green brush monitor indicator (17). The brushes are in good condition.
- ◆ Red brush monitor indicator (18). The brushes are worn and need replacing, return your tool to an authorised Stanley Europe Service Centre in order to have the brushes replaced.

Accessories

The performance of your tool depends on the accessory used. Stanley Fat Max accessories are engineered to high quality standards and designed to enhance the performance of your tool. By using these accessories you will get the very best from your tool.

Maintenance

Your Stanley Fat Max corded/cordless appliance/tool has been designed to operate over a long period of time with a minimum of maintenance. Continuous satisfactory operation depends upon proper tool care and regular cleaning.

Warning! Before performing any maintenance on corded/cordless power tools:

- ◆ Switch off and unplug the appliance/tool.
- ◆ Regularly clean the ventilation slots in your appliance/tool/charger using a soft brush or dry cloth.
- ◆ Regularly clean the motor housing using a damp cloth. Do not use any abrasive or solvent-based cleaner.

- ◆ Regularly open the chuck and tap it to remove any dust from the interior (when fitted).

Mains plug replacement (U.K. & Ireland only)

If a new mains plug needs to be fitted:

- ◆ Safely dispose of the old plug.
- ◆ Connect the brown lead to the live terminal in the new plug.
- ◆ Connect the blue lead to the neutral terminal.

Warning! No connection is to be made to the earth terminal. Follow the fitting instructions supplied with good quality plugs. Recommended fuse: 5 A.

Protecting the environment



Separate collection. This product must not be disposed of with normal household waste.

Should you find one day that your Stanley Fat Max product needs replacement, or if it is of no further use to you, do not dispose of it with household waste. Make this product available for separate collection.



Separate collection of used products and packaging allows materials to be recycled and used again. Re-use of recycled materials helps prevent environmental pollution and reduces the demand for raw materials.

Local regulations may provide for separate collection of electrical products from the household, at municipal waste sites or by the retailer when you purchase a new product.

Technical data

		FME1250 (Type 1)
Input voltage	V_{AC}	230
Power input	W	1250
No-load speed	min^{-1}	0-850
Impact rate	min^{-1}	0-4100
Impact energy per stroke according to EPTA-Procedure 05/2009	J	3.2
Weight	kg	5.4
Max. drilling capacity		
Concrete	mm	32
Steel	mm	13
Wood	mm	40

Australia & New Zealand

Stanley Black & Decker

82 Taryn Drive, Epping, VIC 3076 Australia

Tel.1800 338 002 (Aust) or Tel. 0800 339 258 (NZ)

Level of sound pressure according to EN 60745:

Sound pressure (L_{pA}) 93 dB(A), uncertainty (K) 3 dB(A)

Sound power (L_{WA}) 104 dB(A), uncertainty (K) 3 dB(A)

Vibration total values (triax vector sum) according to EN 60745:

Hammer drilling into concrete ($a_{h,HD}$) 14.2 m/s^2 , uncertainty (K) 1.5 m/s^2

Chiselling ($a_{h,Cheq}$) 13.6 m/s^2 , uncertainty (K) 1.5 m/s^2